



# TREMLOCK 200S FASCIA

SINGLE-PLY APPLICATION

INSTALLATION INSTRUCTIONS

## FOR RADIUS INSTALLATION INSTRUCTIONS SEE PAGE 6

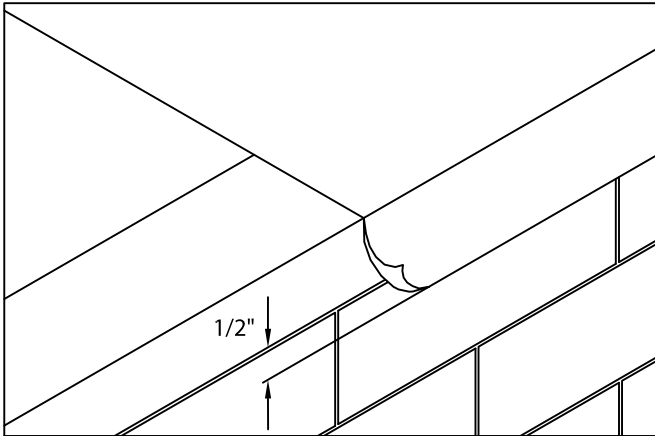

1. POSITION MEMBRANE OVER THE ROOF EDGE AND DOWN OUTSIDE FACE OF WALL, COVERING TREATED WOOD NAILER(S) COMPLETELY. ALLOW  $\frac{1}{2}$ " EXCESS MEMBRANE.

IMPORTANT! OUTSIDE EDGE OF TREATED WOOD NAILER(S) (MINIMUM 2 x 4) SHALL BE ALIGNED FLUSH WITH OR EXTEND SLIGHTLY PAST OUTERMOST EDGE OF WALL.

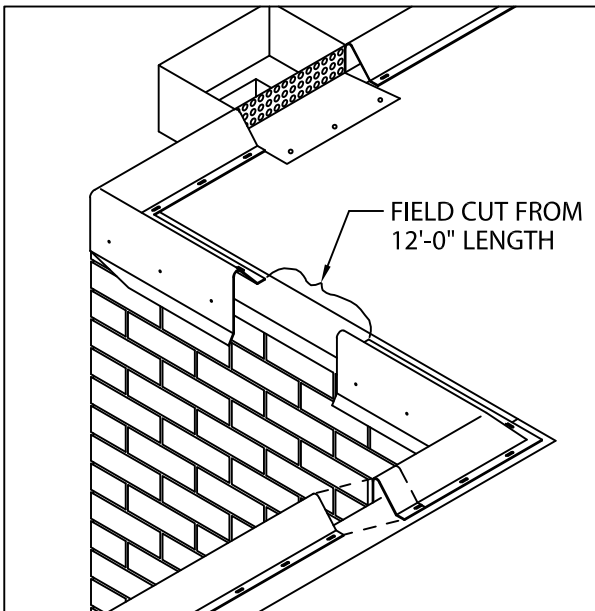

2. LOCATE AND INSTALL MITERS, NAILING THROUGH PRE-SLOTTED FASTENING HOLES ON TOP FLANGE ONLY. DETERMINE AND IDENTIFY LOCATION OF SCUPPERS. LEAVE GAP OF 14  $\frac{1}{2}$ " INCHES FOR SCUPPER LOCATIONS. NEXT LOCATE AND INSTALL SCUPPERS. SEE PAGES 4 AND 5 FOR DETAILED INSTRUCTIONS ON INSTALLING SCUPPERS. THEN INSTALL THE 12'-0" SECTIONS OF WATERDAM FROM RIGHT TO LEFT (AS SEEN FROM ROOF TOP) BY NAILING THROUGH SLOTTED HOLES PROVIDED PER JOB REQUIREMENTS. FIELD CUT SECTIONS AS NECESSARY. LAP WATERDAM JOINTS 1".

NOTE: DO NOT ATTACH FACE OF WATERDAM AT THIS TIME.

PROVIDED WATERDAM FASTENER: 1  $\frac{1}{4}$ " RING SHANK GALVANIZED ROOFING NAILS.

CAUTION : INSTALLERS SHALL WEAR PROTECTIVE EYEWEAR TO PREVENT SERIOUS INJURY.



# TREMLOCK 200S FASCIA

SINGLE-PLY APPLICATION

INSTALLATION INSTRUCTIONS

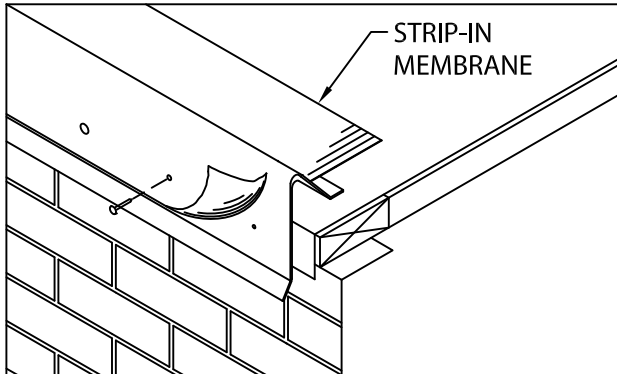

3. POSITION STRIP-IN MEMBRANE OVER AND DOWN WATERDAM FACE APPROXIMATELY 1" BELOW RAISED FASTENING HOLES (PROVIDED). TAKE CARE TO AVOID BRIDGING OF MEMBRANE. LOCATE AND NAIL MEMBRANE AT 12" O.C. THROUGH ALL RAISED HOLES ON OUTSIDE FACE USING 1 1/4" RING SHANK NAILS PROVIDED.

NOTE: FOLLOW GENERAL RECOMMENDATIONS OF TREMCO'S APPLICATION OF MATERIALS OVER THE ROOF EDGE.

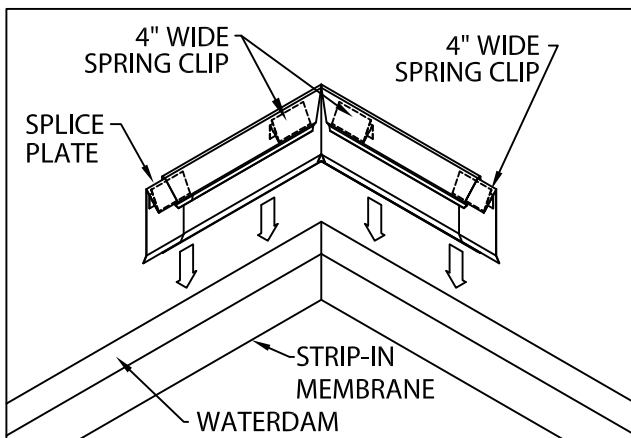

4. INSTALL MITER COVERS FIRST. INSERT ONE SPLICE PLATE AND ONE 4" WIDE SPRING CLIP INTO EACH END OF MITER COVER, (SEE DETAIL ON PAGE 3 FOR PROPER SPRING INSTALLATION). PLACE TWO 4" WIDE SPRING CLIPS INTO CORNERS OF MITER AS SHOWN. INSTALL MITER COVERS BY PUSHING DOWNWARD UNTIL COVER IS ENGAGED ALONG ENTIRE MITER.

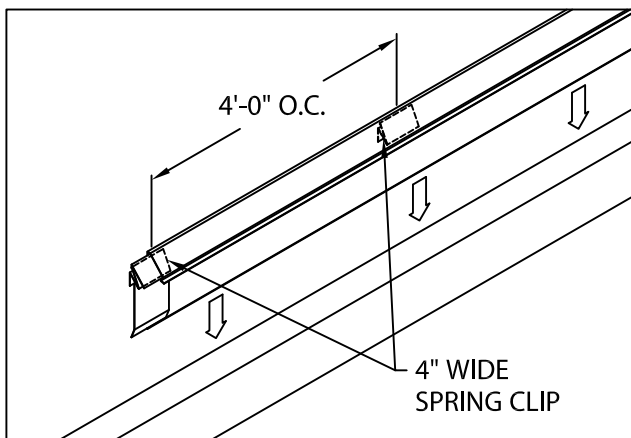

5. INSTALL 12'-0" FASCIA COVER SECTIONS. INSERT ONE SPLICE PLATE AND ONE 4" WIDE SPRING CLIP UNDER FAR END OF FASCIA COVER. PLACE 4" WIDE SPRING CLIPS INTO COVER AT 4'-0" O.C. INSTALL COVER BY PUSHING DOWNWARD UNTIL FASCIA COVER IS ENGAGED TO WATERDAM ALONG ENTIRE LENGTH. CONTINUE TO INSTALL FASCIA COVERS, LEAVING A 3/8" SPACE BETWEEN COVERS. FIELD CUT WHERE NECESSARY USING FINE TOOTH HACKSAW.

**CAUTION:** REMOVE PROTECTIVE FILM IMMEDIATELY AFTER INSTALLATION, WHERE APPLICABLE.



# TREMLOCK 200S FASCIA

SINGLE-PLY APPLICATION

INSTALLATION INSTRUCTIONS

## SPRING DETAIL

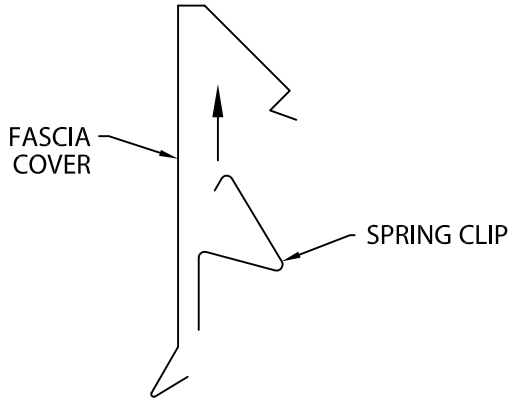

SIMPLY POSITION SPRING CLIP AS SHOWN AND PUSH STRAIGHT UP INTO COVER UNTIL SNAP LOCK OCCURS.

## TYPICAL INSTALLATION

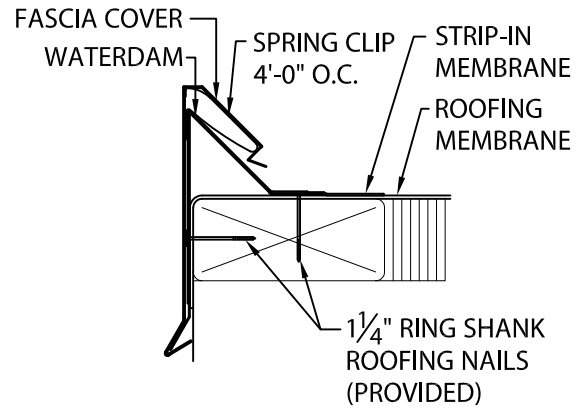



# TREMLOCK 200S FASCIA

SINGLE-PLY APPLICATION

## SCUPPER INSTALLATION INSTRUCTIONS

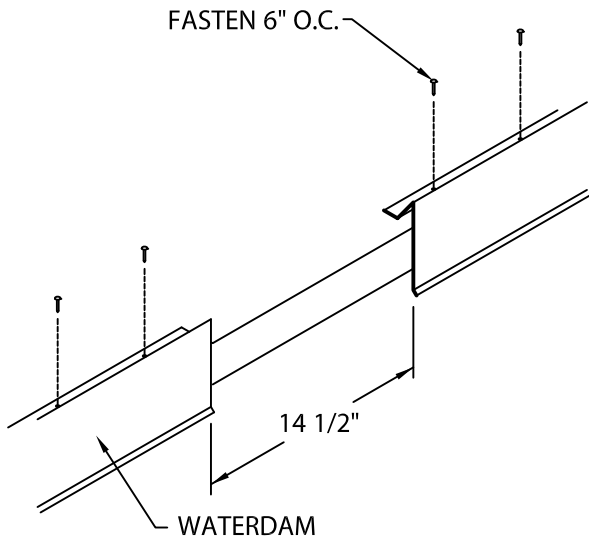

**STEP 1 - WATERDAM / ROOFING MEMBRANE**  
 DETERMINE LOCATION OF SCUPPER AND SPACE WATERDAM 14 1/2" APART. FASTEN WATERDAM FLANGE 6" O.C. WITH PROVIDED 1 1/4" RING SHANK ROOFING NAILS.

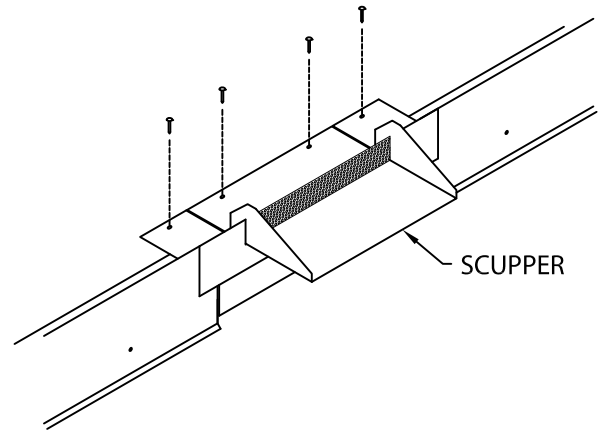

**STEP 2- SCUPPER**  
 INSTALL SCUPPER WITH PROVIDED 1 1/4" RING SHANK ROOFING NAILS. SET SCUPPER FLANGE IN A CONTINUOUS BEAD OF NON-CURING SEALANT.

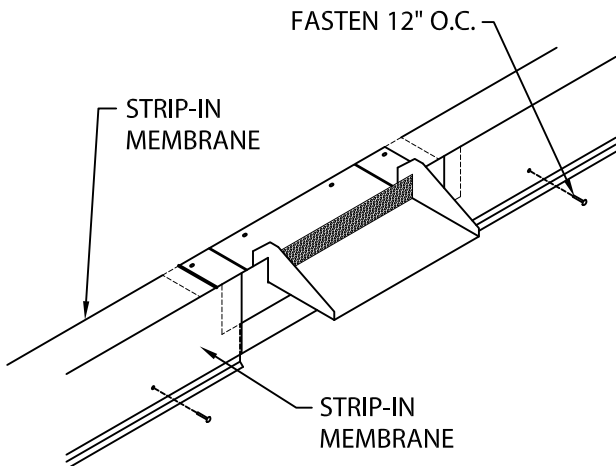

**STEP 3 - WATERDAM**  
 POSITION STRIP-IN MEMBRANE OVER AND DOWN WATERDAM FACE APPROXIMATELY 1" BELOW RAISED FASTENING HOLES. TAKE CARE TO AVOID BRIDGING OF MEMBRANE. LOCATE AND NAIL MEMBRANE AT 12" O.C. THROUGH ALL RAISED HOLES ON OUTSIDE FACE USING 1 1/4" RING SHANK ROOFING NAILS PROVIDED.

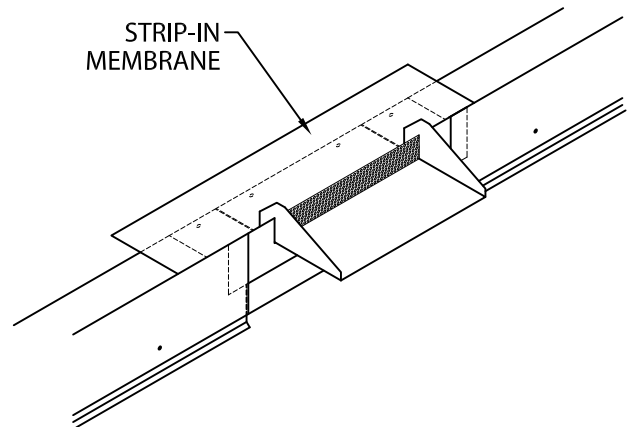

**STEP 4 - STRIP-IN MEMBRANE**  
 STRIP-IN SCUPPER FLANGE.



PHONE: 262-953-2666  
 EDGESYSTEMS@TREMCOINC.COM  
 WWW.TREMCOROOFING.COM

DATE: 07/20/18  
 DRN BY: JJC  
 CKD BY: SAK

SHT.# 4 OF 7  
 DWG# 60110-29286

A



# TREMLOCK 200S FASCIA

SINGLE-PLY APPLICATION

## SCUPPER INSTALLATION INSTRUCTIONS

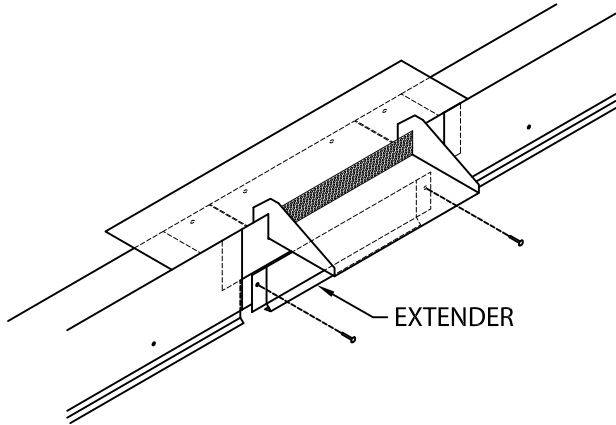

### STEP 5- EXTENDER

CENTER EXTENDER BELOW SCUPPER AND FASTEN THROUGH PRE-SLOTTED HOLES WITH PROVIDED NAILS AS SHOWN.

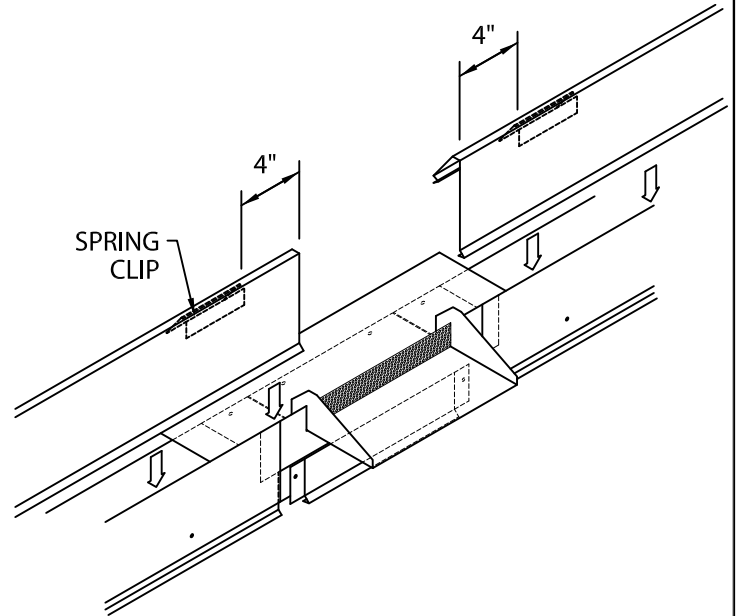

### STEP 6- SPRING CLIP / FASCIA COVER

PLACE SPRING CLIPS 4" FROM END OF FASCIA COVER. INSTALL COVER BY PUSHING DOWNWARD UNTIL FASCIA COVER IS ENGAGED TO WATERDAM. FASCIA COVER SHOULD FIT TIGHT AGAINST SIDES OF SCUPPER.



# TREMLOCK 200S FASCIA

SINGLE-PLY APPLICATION

## RADIUS INSTALLATION INSTRUCTIONS

### RADIUS INSTALLATION INSTRUCTIONS

1. FOLLOW DIRECTIONS ON PAGES 1 AND 2 FOR INSTALLING WATERDAM, ROOF MEMBRANE AND STRIP-IN MEMBRANE.

2. INSTALL 12'-0" FASCIA COVER SECTIONS. INSERT ONE SPLICE PLATE AND ONE 4" WIDE SPRING CLIP UNDER FAR END OF FASCIA COVER. PLACE 4" WIDE SPRING CLIPS INTO COVER AT 4'-0" O.C. INSTALL COVER BY PUSHING DOWNWARD UNTIL FASCIA COVER IS ENGAGED TO WATERDAM ALONG ENTIRE LENGTH. CONTINUE TO INSTALL FASCIA COVERS, LEAVING A 3/8" SPACE BETWEEN COVERS. FIELD CUT WHERE NECESSARY USING FINE TOOTH HACKSAW.

**CAUTION:** REMOVE PROTECTIVE FILM IMMEDIATELY AFTER INSTALLATION, WHERE APPLICABLE.

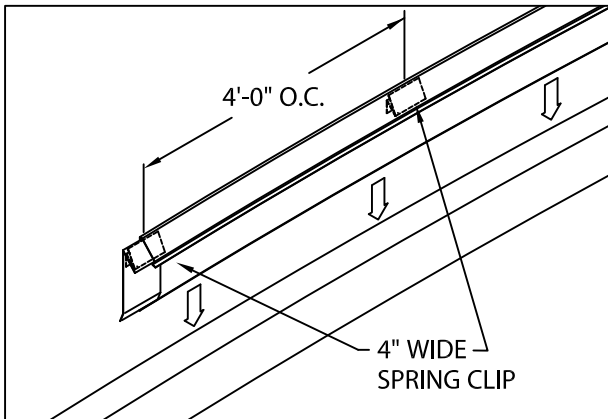

### SPRING DETAIL

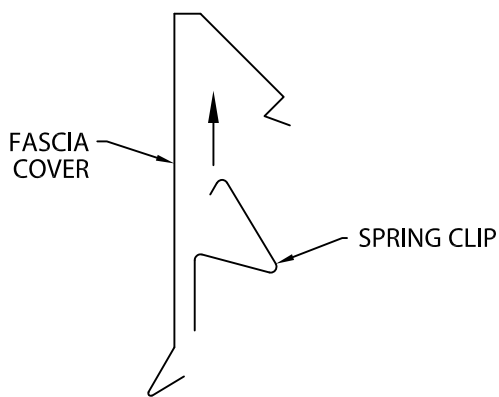

SIMPLY POSITION SPRING CLIP AS SHOWN AND PUSH STRAIGHT UP INTO COVER UNTIL SNAP LOCK OCCURS.

### TYPICAL RADIUS INSTALLATION

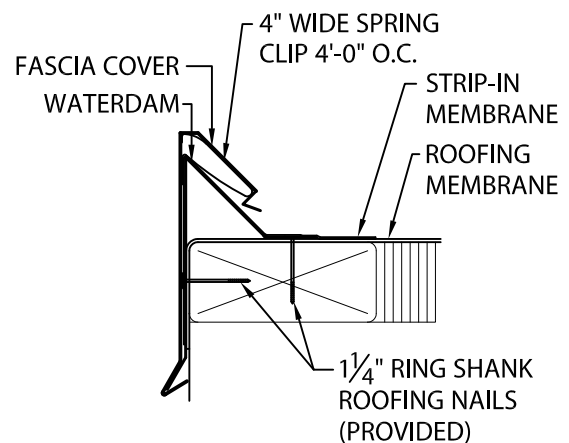



# TREMLOCK 200S FASCIA

SINGLE-PLY APPLICATION

INSTALLATION INSTRUCTIONS

## COMPONENT LIST

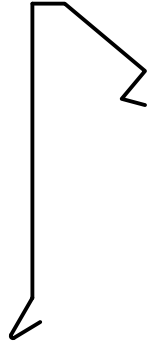

FASCIA COVER  
12'-0" LENGTHS

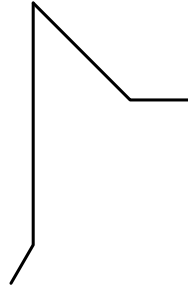

WATERDAM  
12'-0" LENGTHS

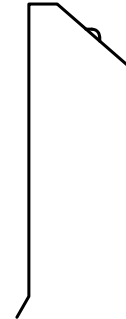

SPLICE PLATE  
3 1/2" WIDE

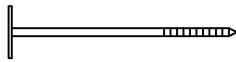

1 1/4" RING SHANK  
ROOFING NAIL

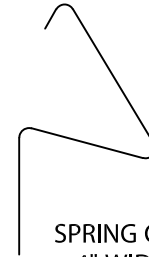

SPRING CLIP  
4" WIDE

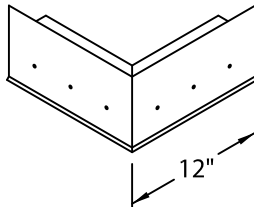

WATERDAM  
OUTSIDE MITER

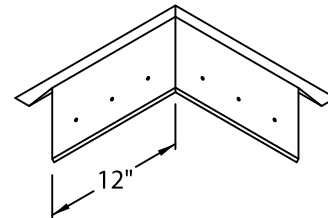

WATERDAM  
INSIDE MITER

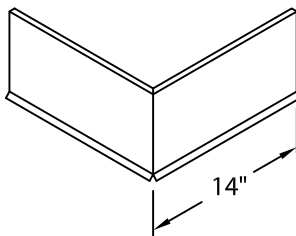

FASCIA COVER  
OUTSIDE MITER

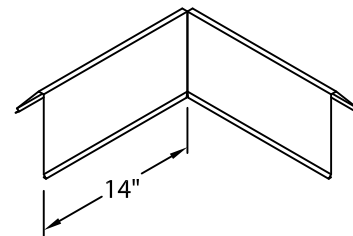

FASCIA COVER  
INSIDE MITER